

Assembly Instruction - Conference
Monteringsanvisning - Konferens
Montageanleitung - Konferenz

2-columns/2-ben/2-Beine4
 3-columns/3-ben/3-Beine 9
 4-columns/4-ben/4-Beine17

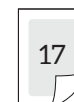

2-columns/2-ben/2-Beine

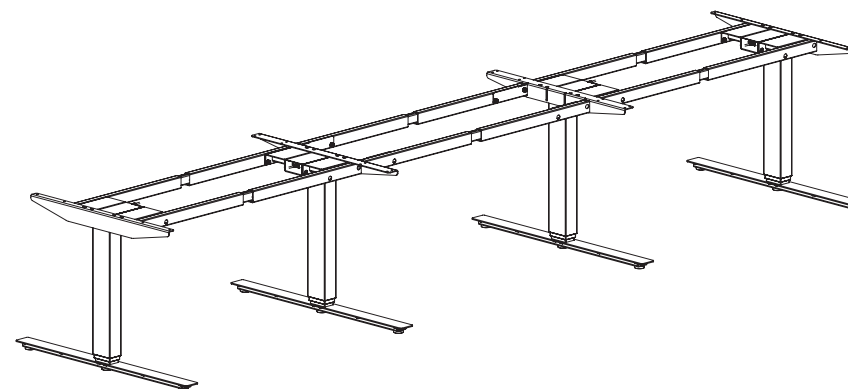
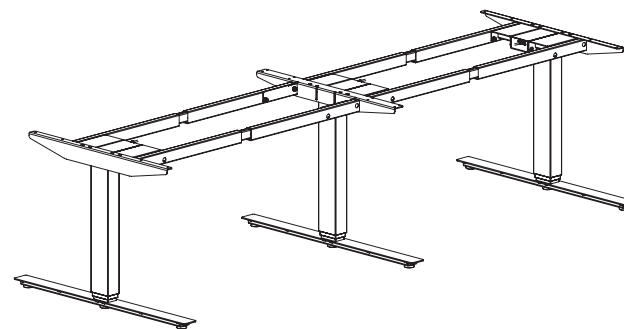
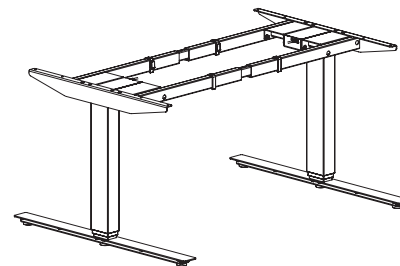
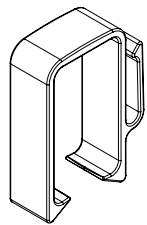
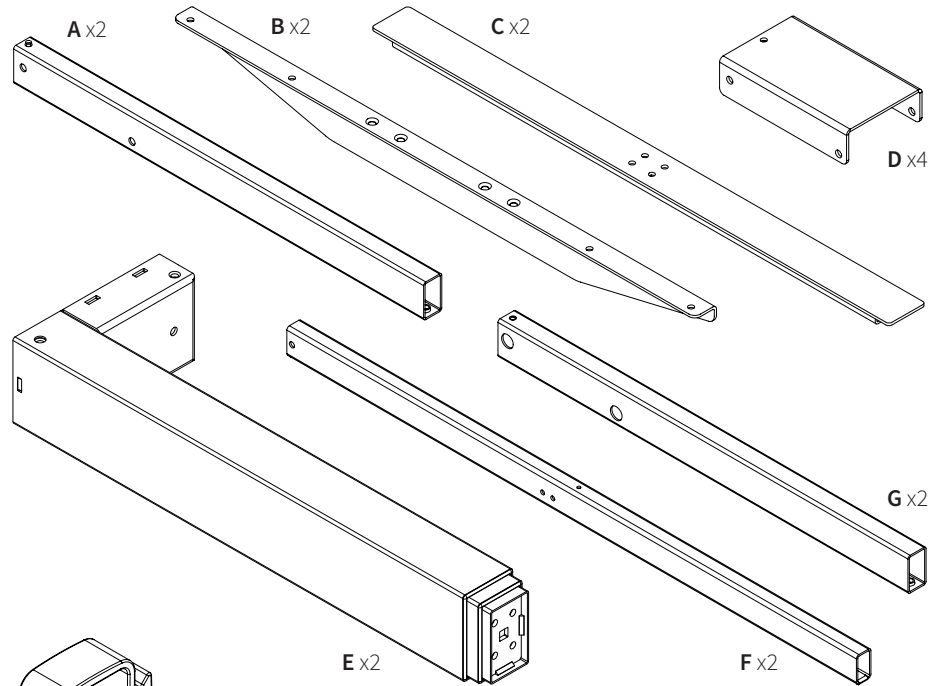

H x4

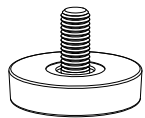

I x6
M8



J x16
M8x20



K x8
M8



L x4
M6x16



M x8
M8x20



N x8
M8x8



O x12
M4,5x20

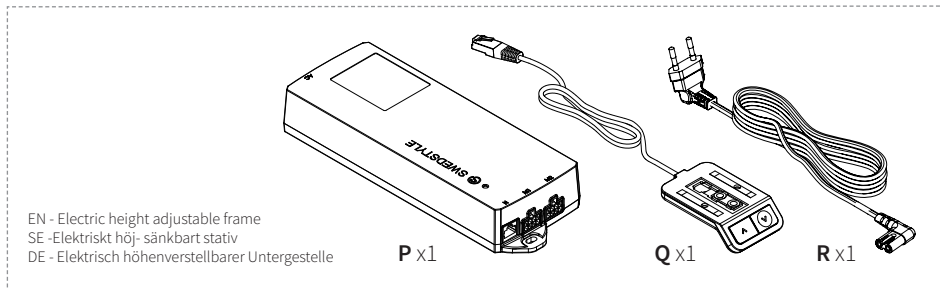

EN - Electric height adjustable frame
SE - Elektriskt höj- sänkbart stativ
DE - Elektrisch höhenverstellbarer Untergestelle

P x1

Q x1

R x1

1.

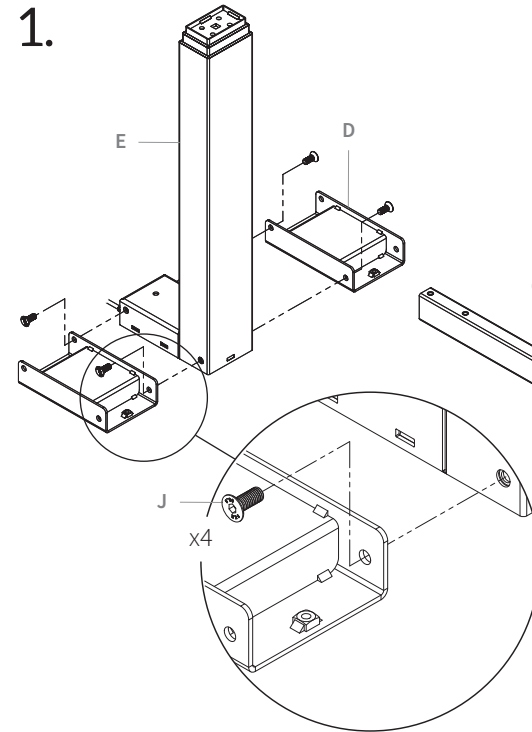

2.

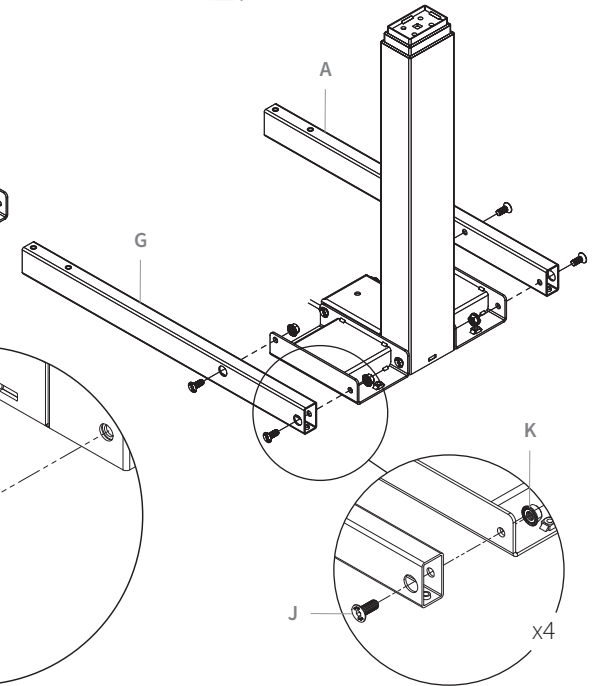

3.

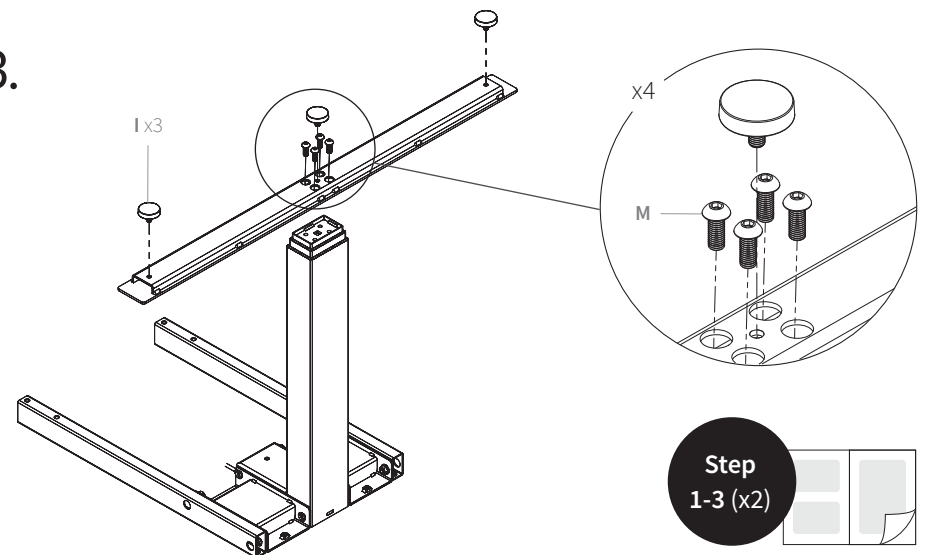

Step 1-3 (x2)

4.

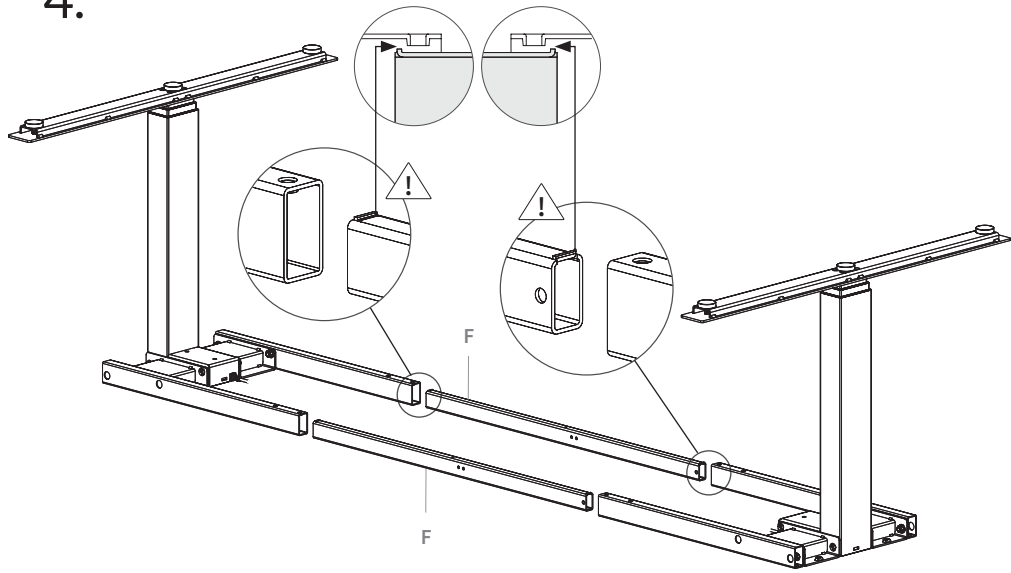

6.

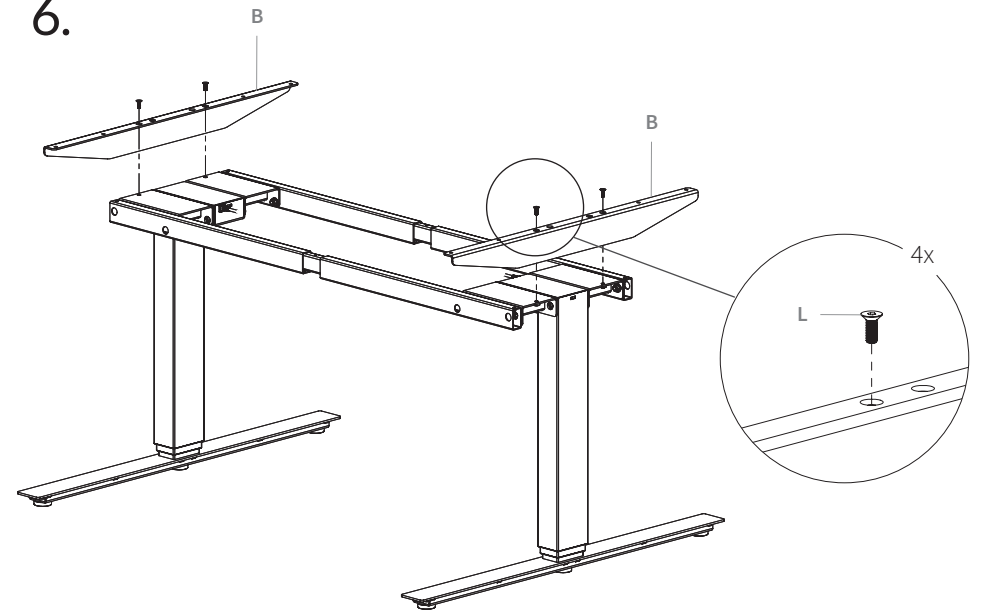

5.

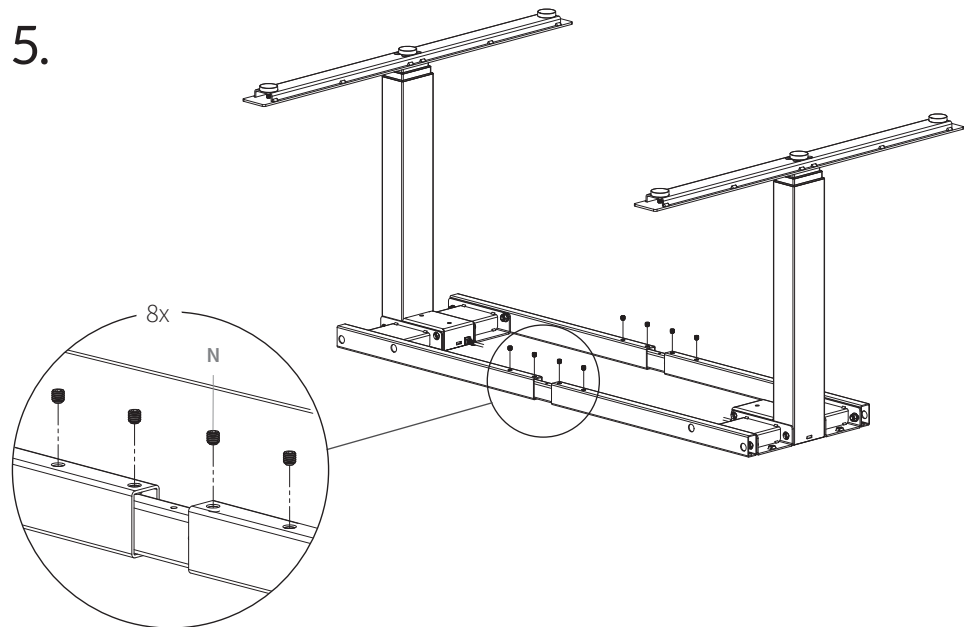

7.

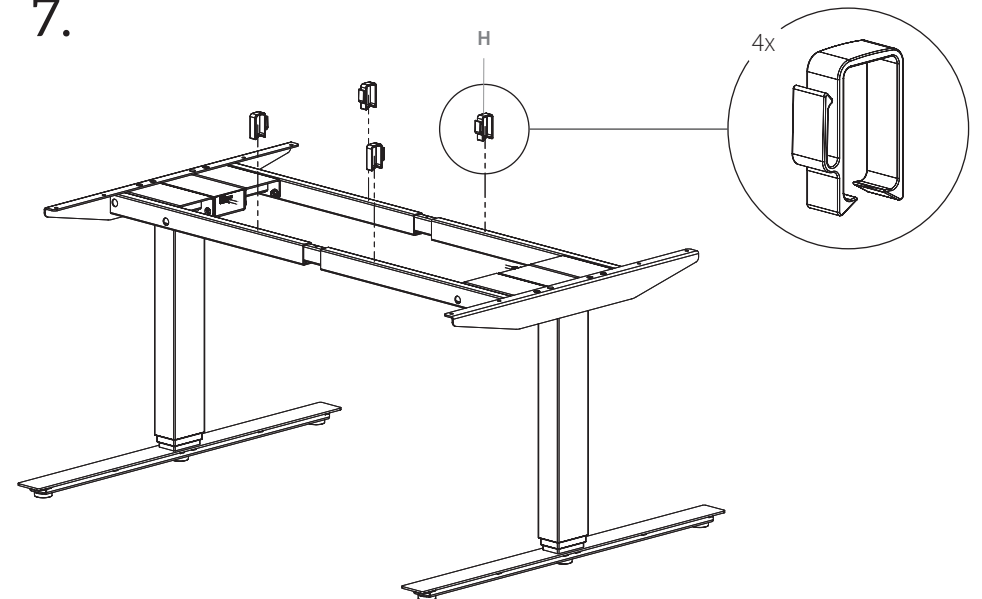

8.

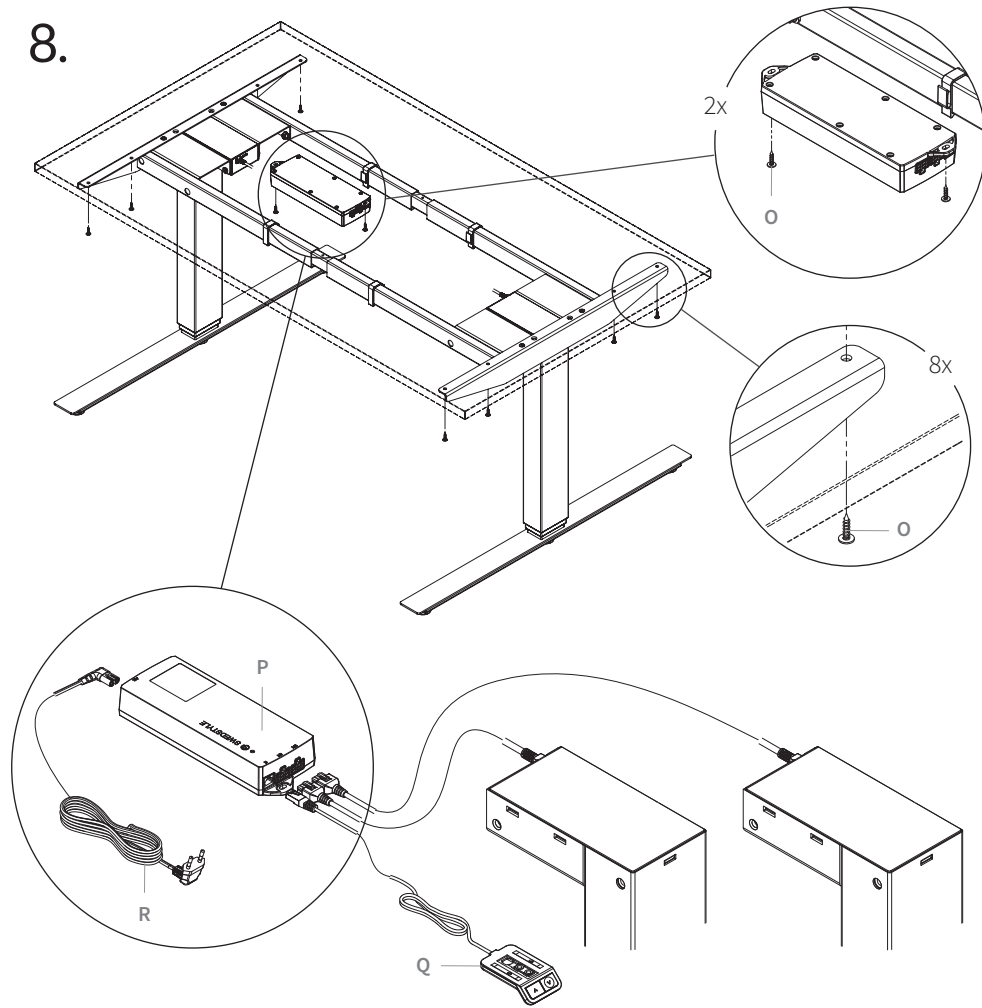

**Electric height adjustable
A-2 AERO Conference**

1. Connect the motor cables (E), hand control (P) and power cord (Q) to the control box (O).
2. NOTE! All cables must be connected to control box before you plug in the power.
3. Before using the table, perform the reset procedure. See page 26.

**Elektriskt justerbart höj-sänkbart
A-2 AERO Konferens**

1. Koppla in motorkablarna (E), handkontroll (P) och strömsladd (Q) till styrboxen (O).
2. OBS! Alla kablar måste vara inkopplade i styrboxen innan den strömsätts.
3. Innan stativet används måste en nollställning utföras. Se sid 26.

**Elektrisch höhenverstellbarer
A-2 AERO Konferenz**

1. Verbinden Sie die Motorkabel (E), die Handschalter (P) und das Netzkabel (Q) mit der Steuerbox (O).
2. HINWEIS! Alle Kabel müssen vor dem Einschalten in die Steuerbox mit dem Stromkabel verbunden werden.
3. Vor der Verwendung des Gestell muss ein Reset durchgeführt werden. Siehe Seite 26.

3-columns/3-ben/3-Beine

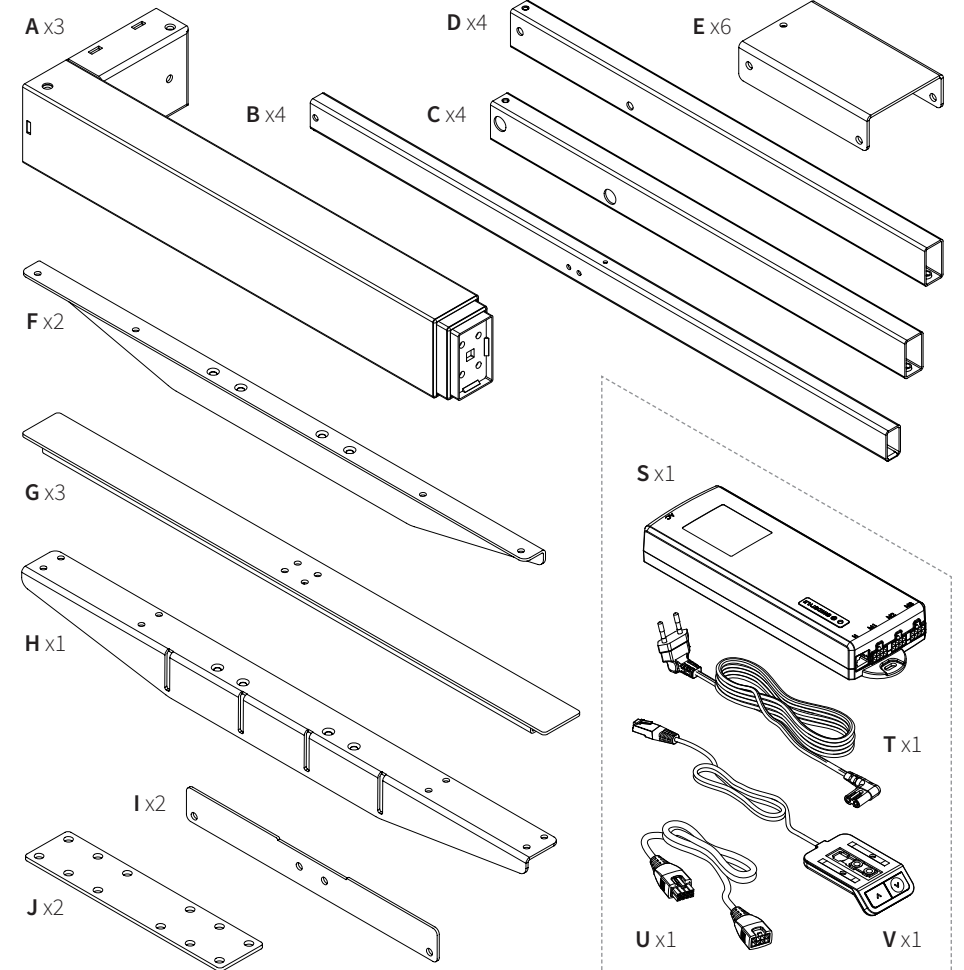

EN - Electric height adjustable frame
SE - Elektriskt höj- sänkbart stativ
DE - Elektrisch höhenverstellbarer Untergestelle

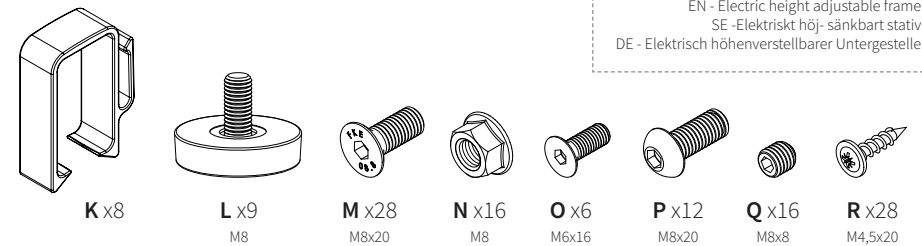

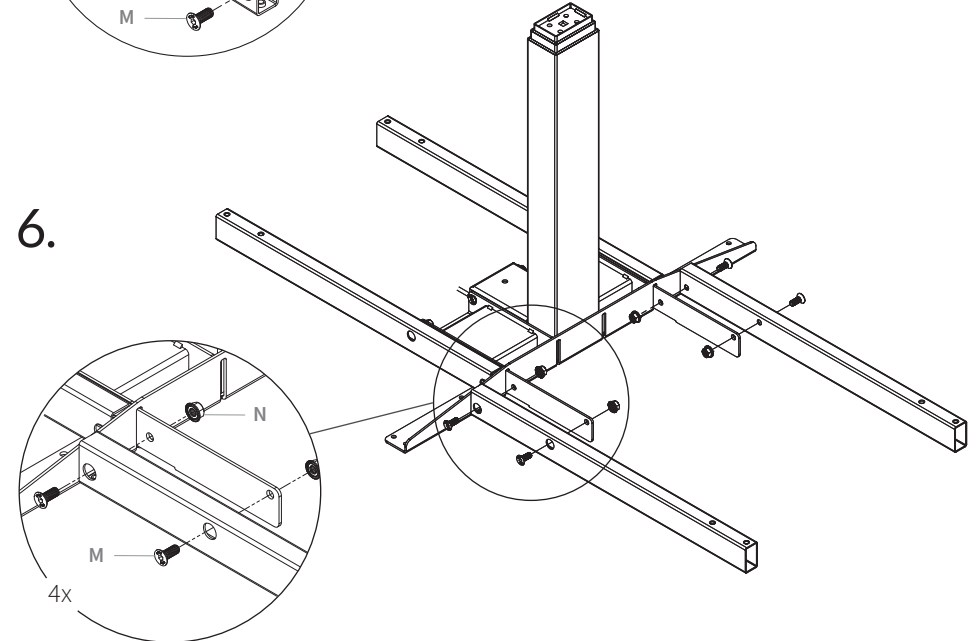
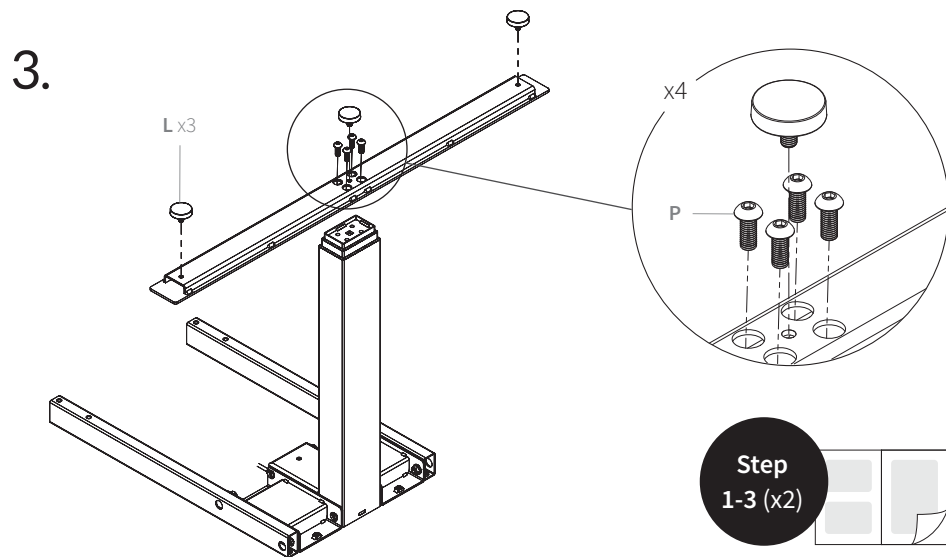
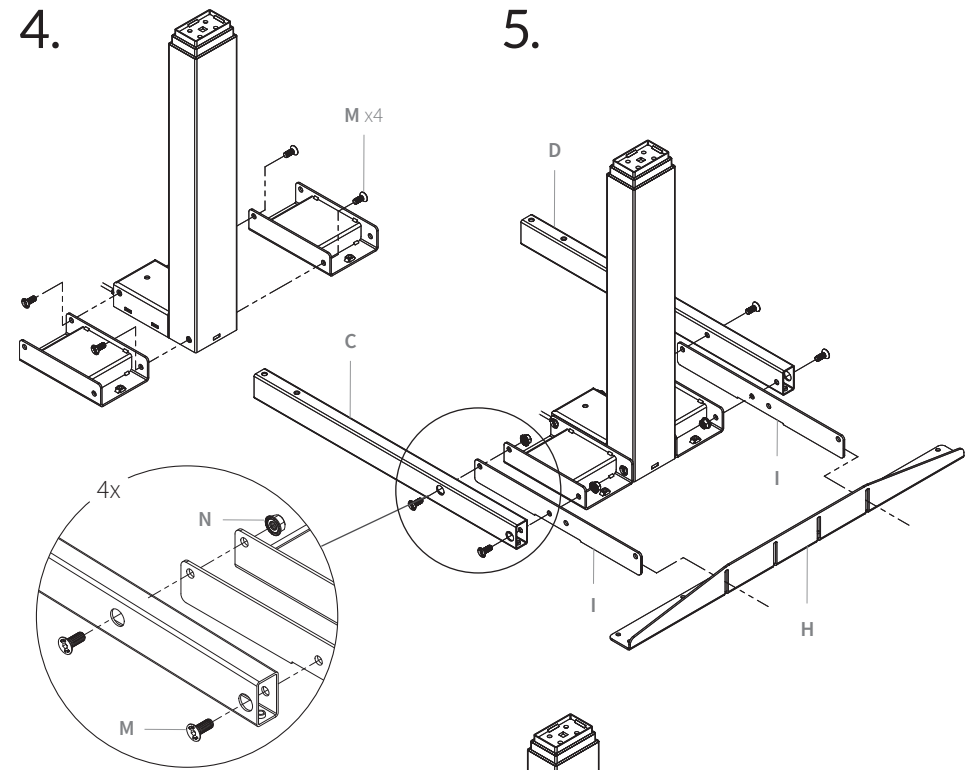
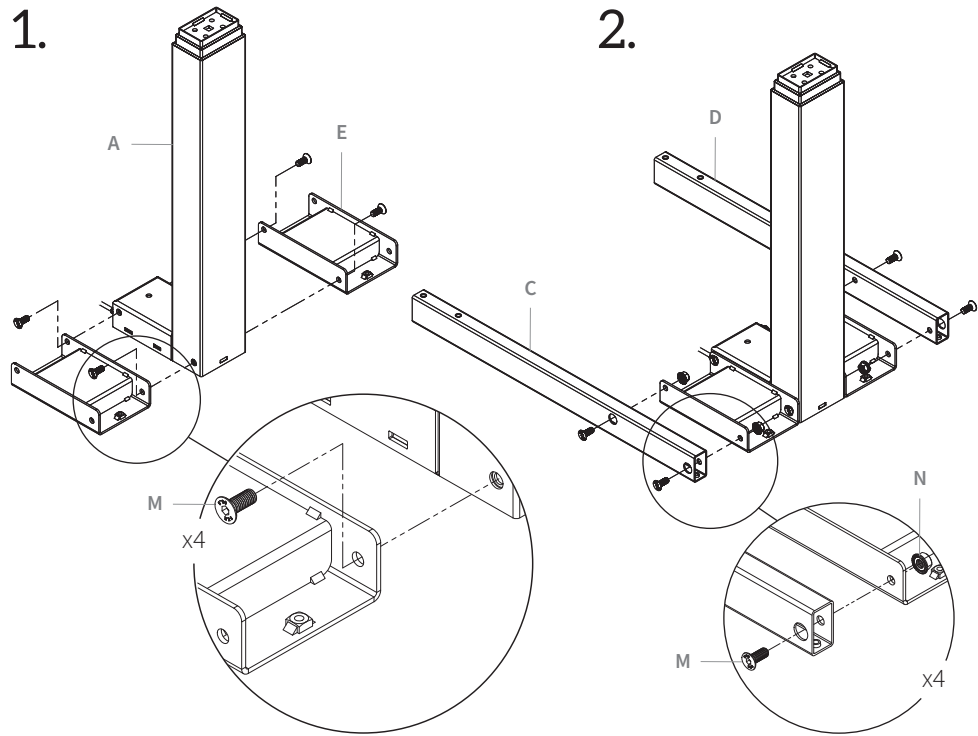

7.

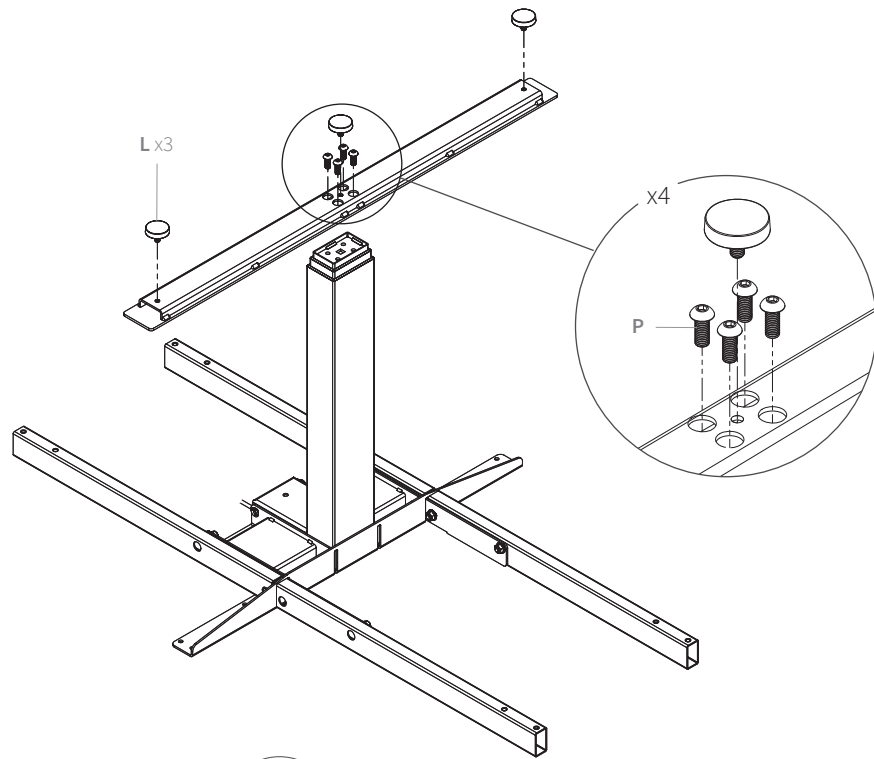

8.

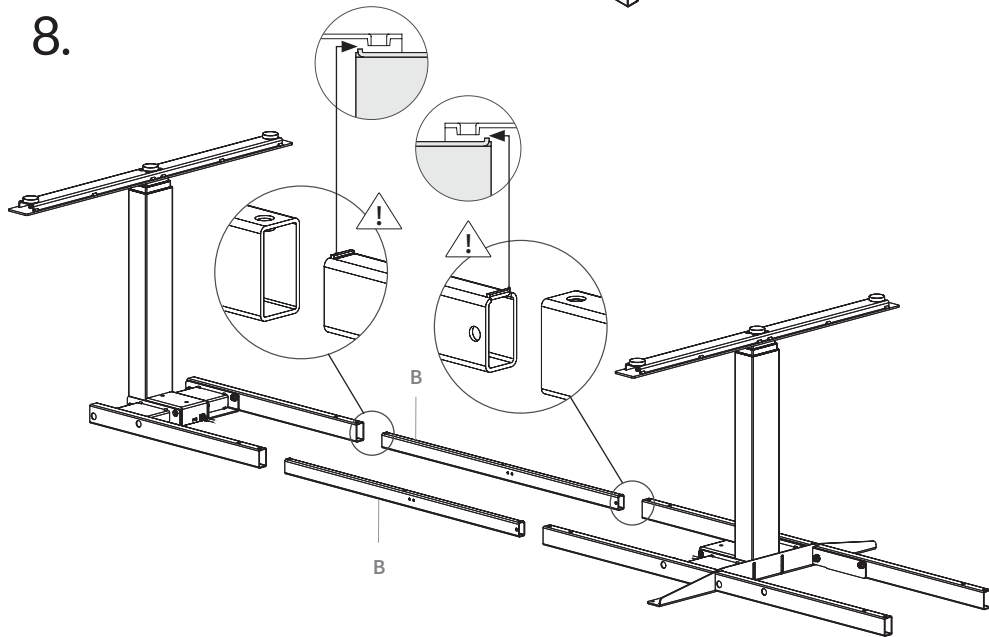

9.

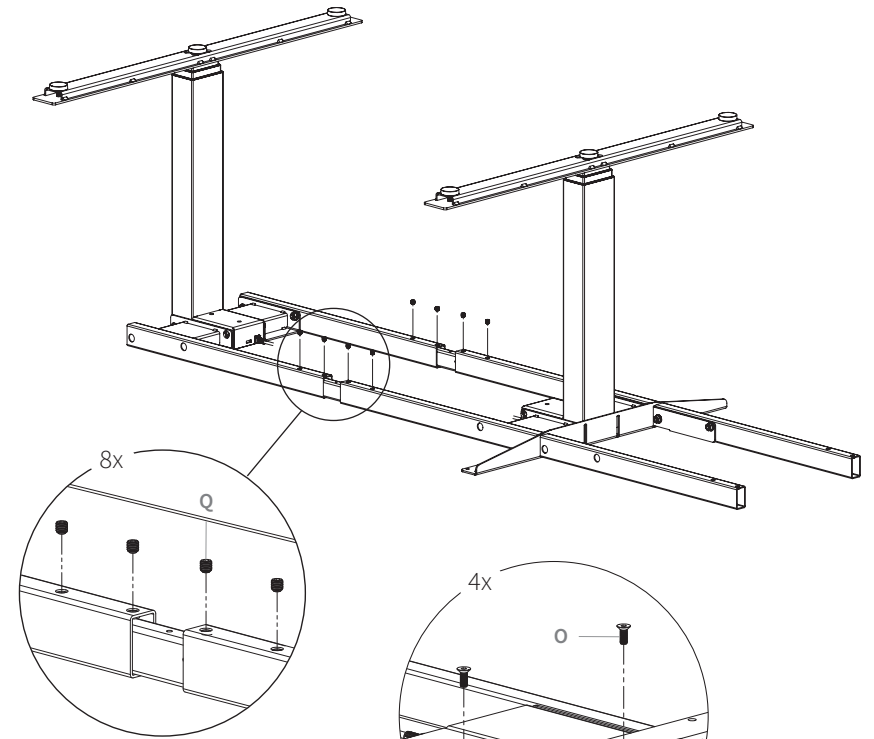

10.

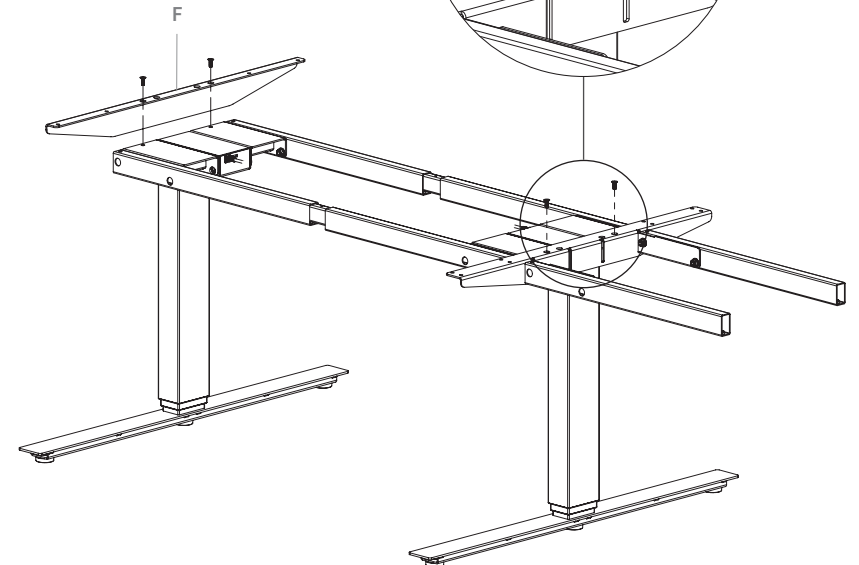

11.

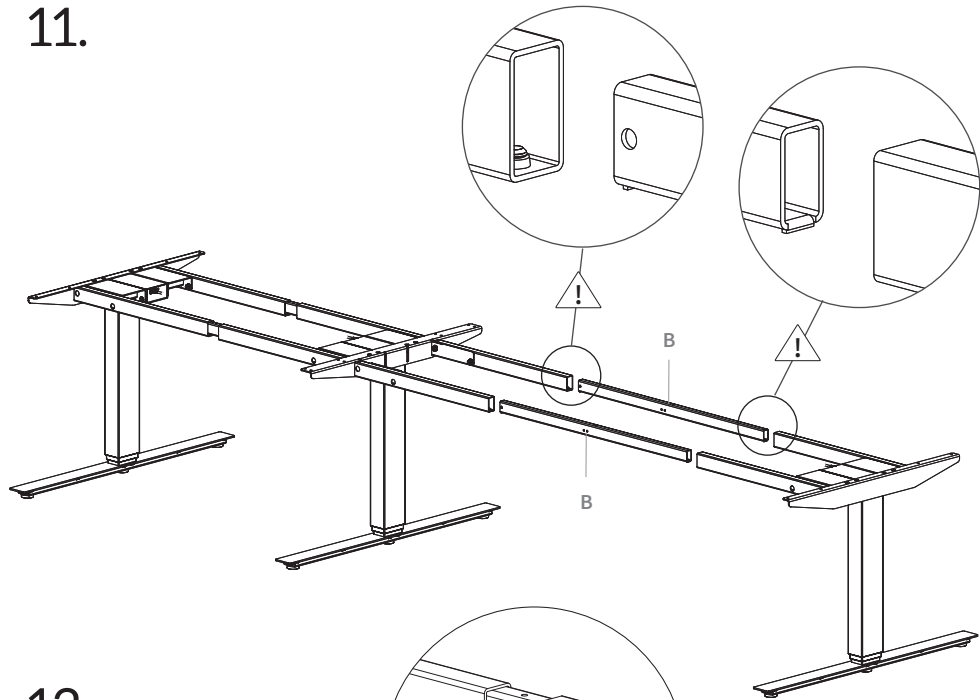

12.

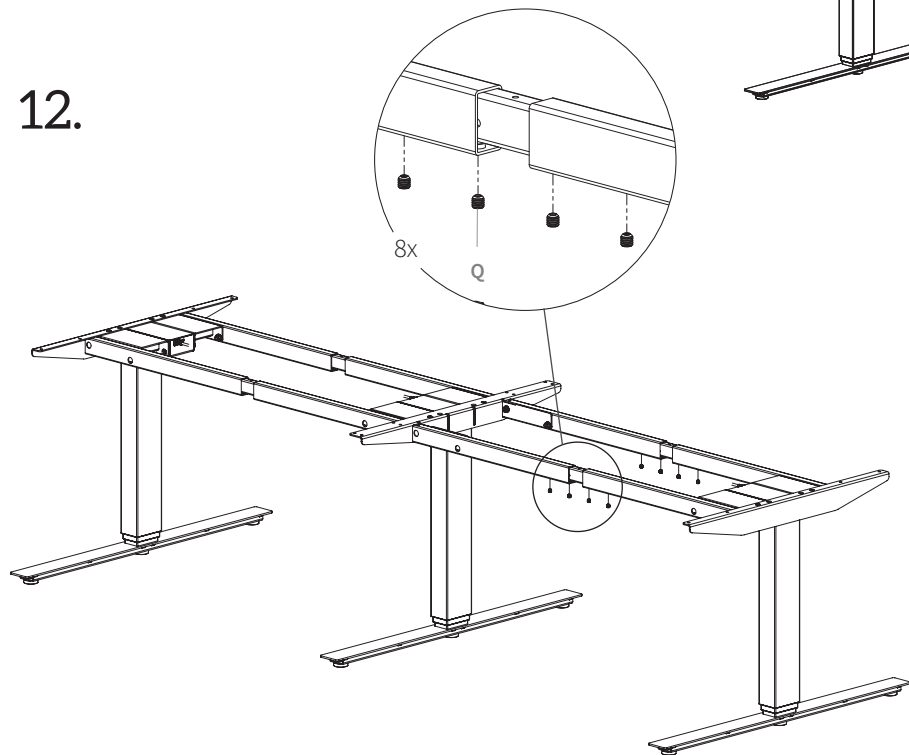

13.

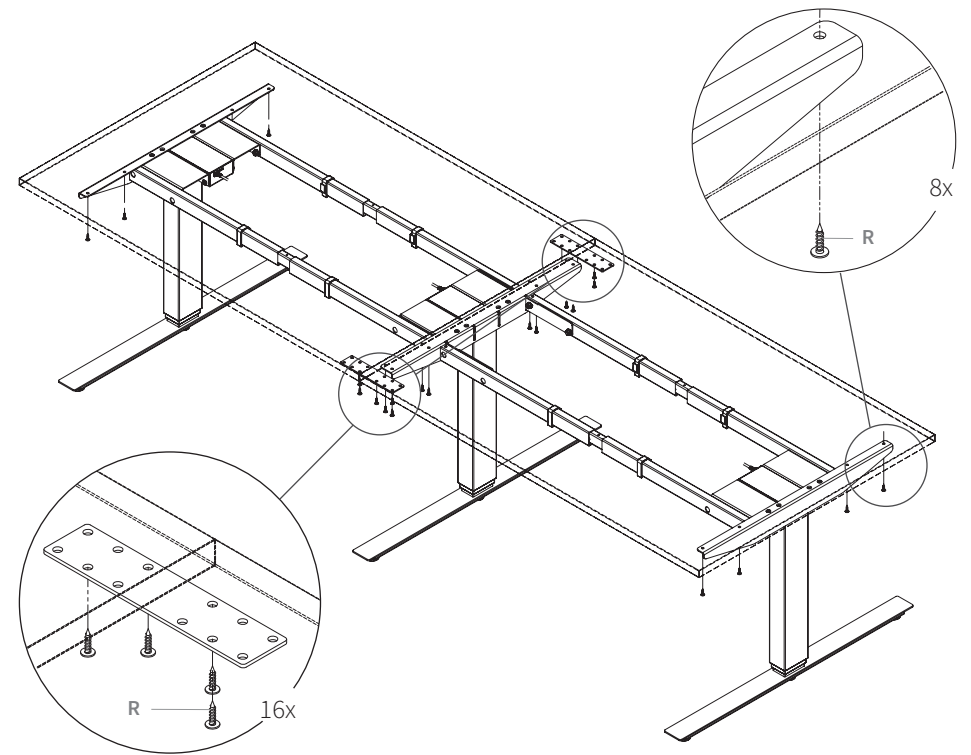
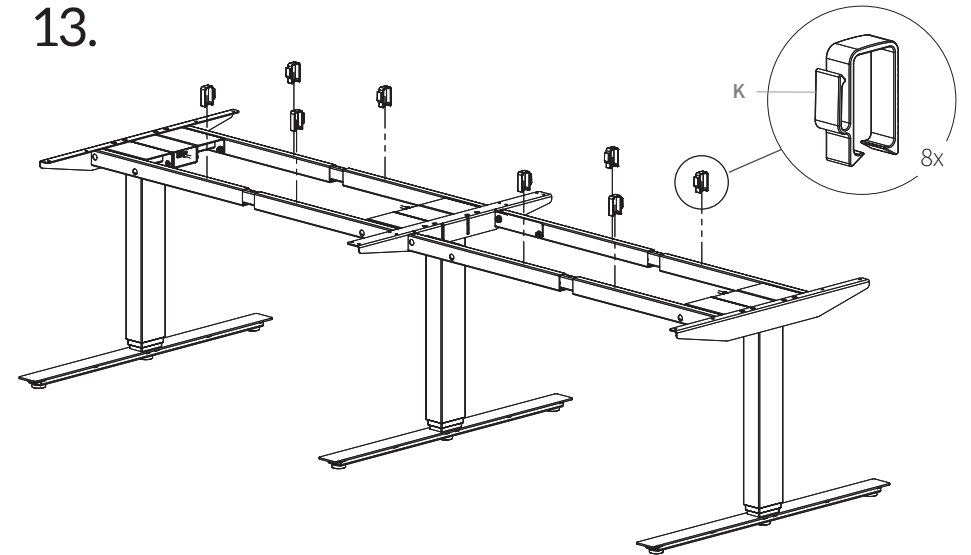

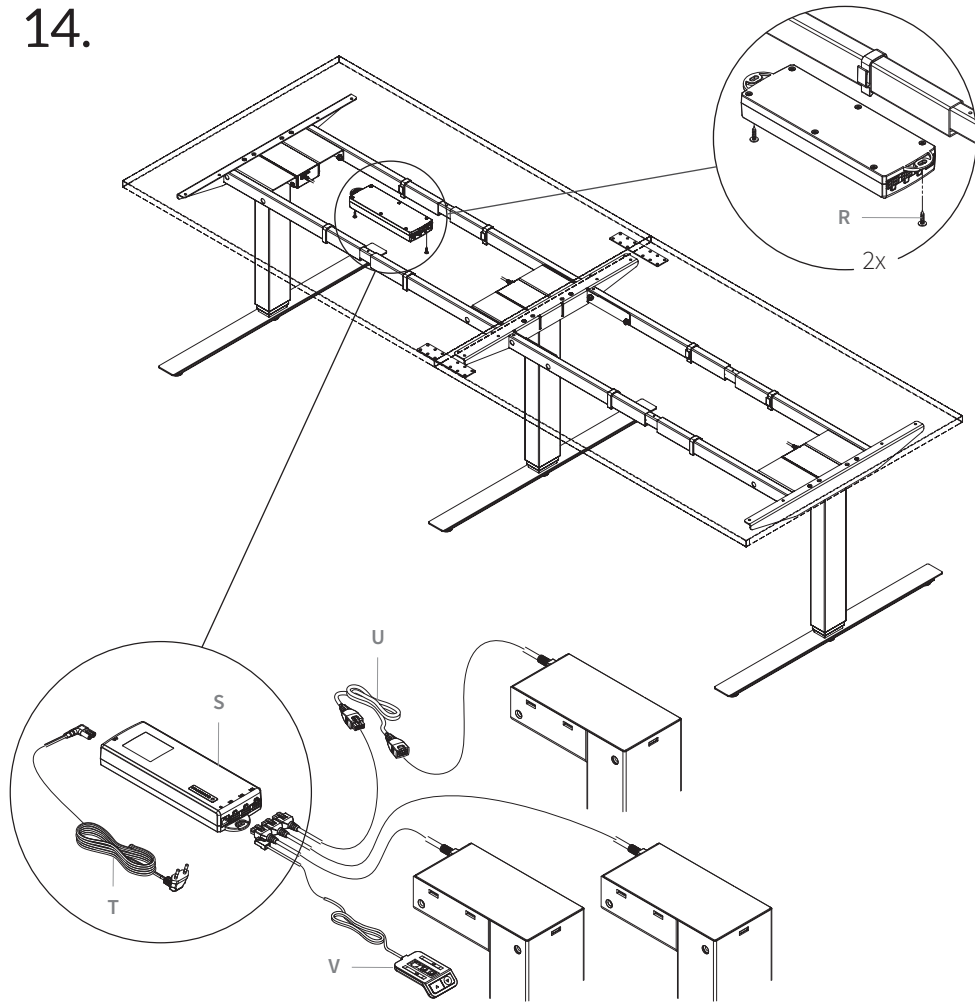

**Electric height adjustable
A-3 AERO Conference**

1. Connect the motor cables (E), hand control (P) and power cord (Q) to the control box (O).
2. NOTE! All cables must be connected to control box before you plug in the power.
3. Before using the table, perform the reset procedure. See page 26.

**Elektriskt justerbart höj-sänkbart
A-3 AERO Konferens**

1. Koppla in motorkablarna (E), handkontroll (P) och strömladd (Q) till styrboxen (O).
2. OBS! Alla kablar måste vara inkopplade i styrboxen innan den strömsätts.
3. Innan stativet används måste en nollställning utföras. Se sid 26.

**Elektrisch höhenverstellbarer
A-3 AERO Konferenz**

1. Verbinden Sie die Motorkabel (E), die Handschalter (P) und das Netzkabel (Q) mit der Steuerbox (O).
2. HINWEIS! Alle Kabel müssen vor dem Einschalten in die Steuerbox mit dem Stromkabel verbunden werden.
3. Vor der Verwendung des Gestell muss ein Reset durchgeführt werden. Siehe Seite 26.

4-columns/4-ben/4-Beine

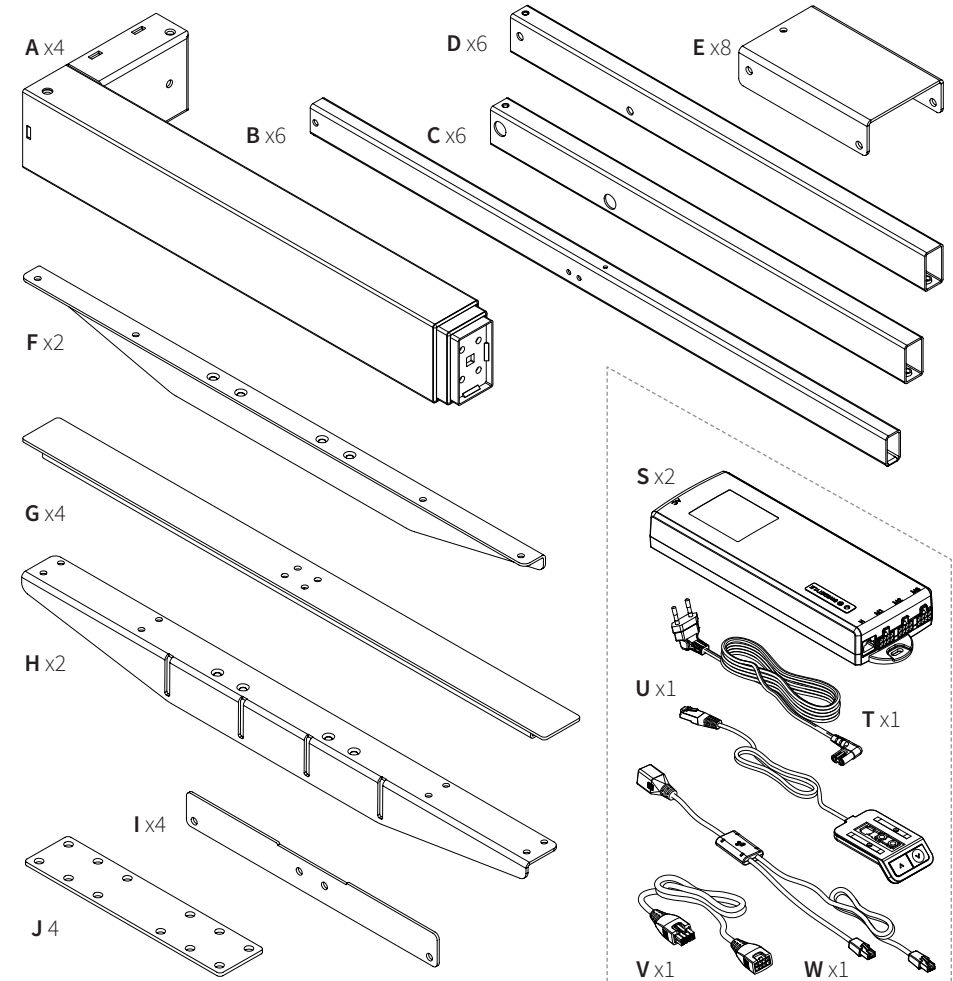

EN - Electric height adjustable frame
SE - Elektriskt höj- sänkbart stativ
DE - Elektrisch höhenverstellbarer Untergestelle

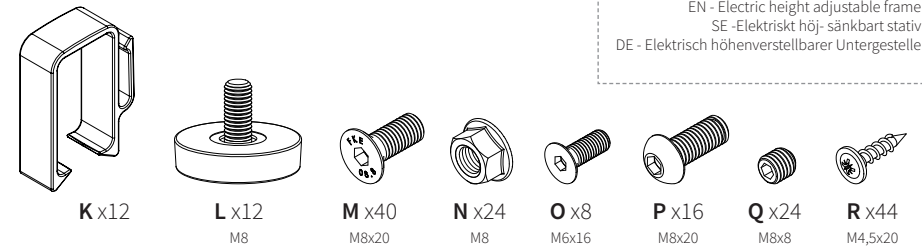

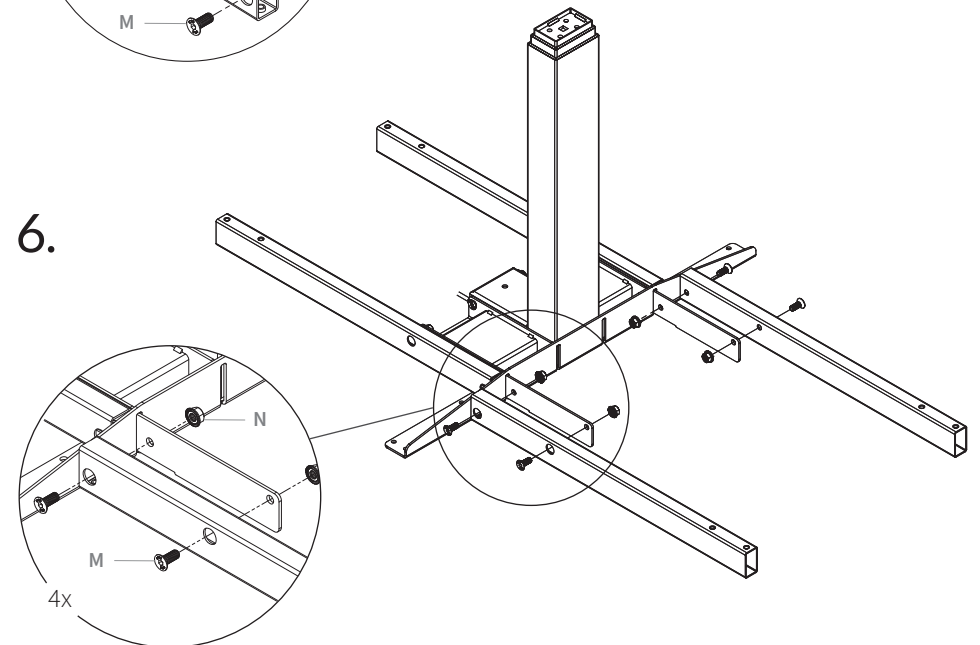
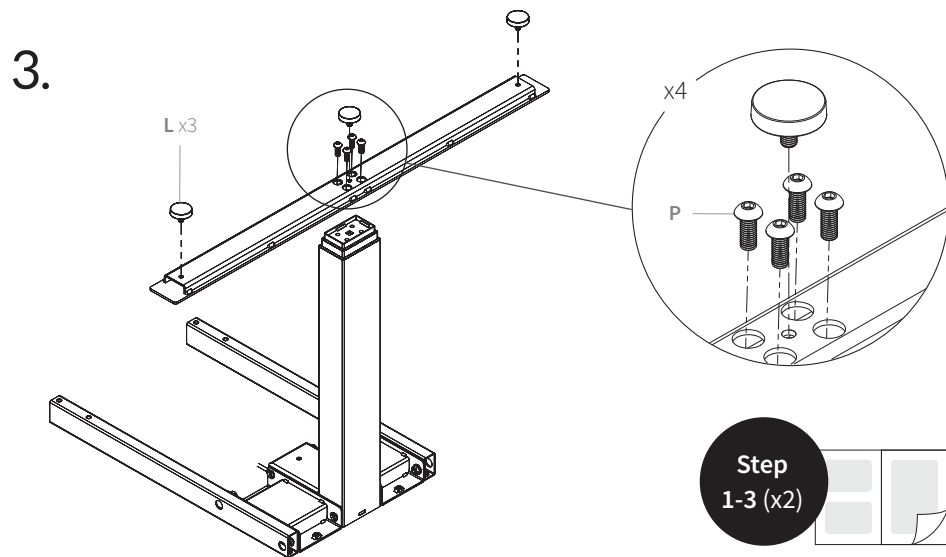
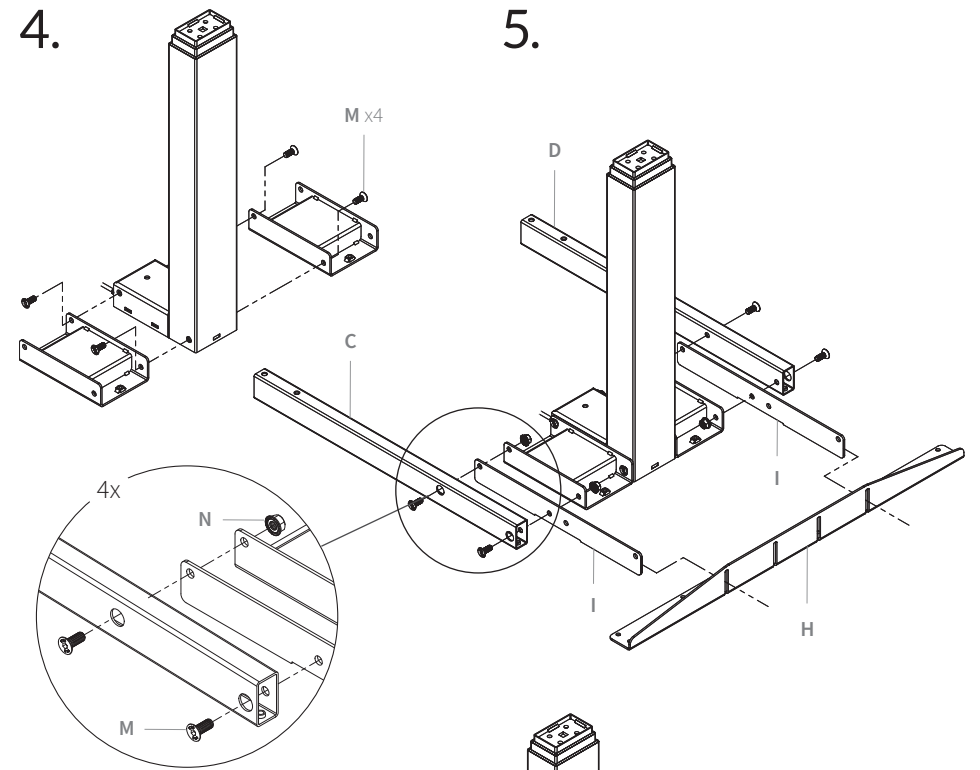
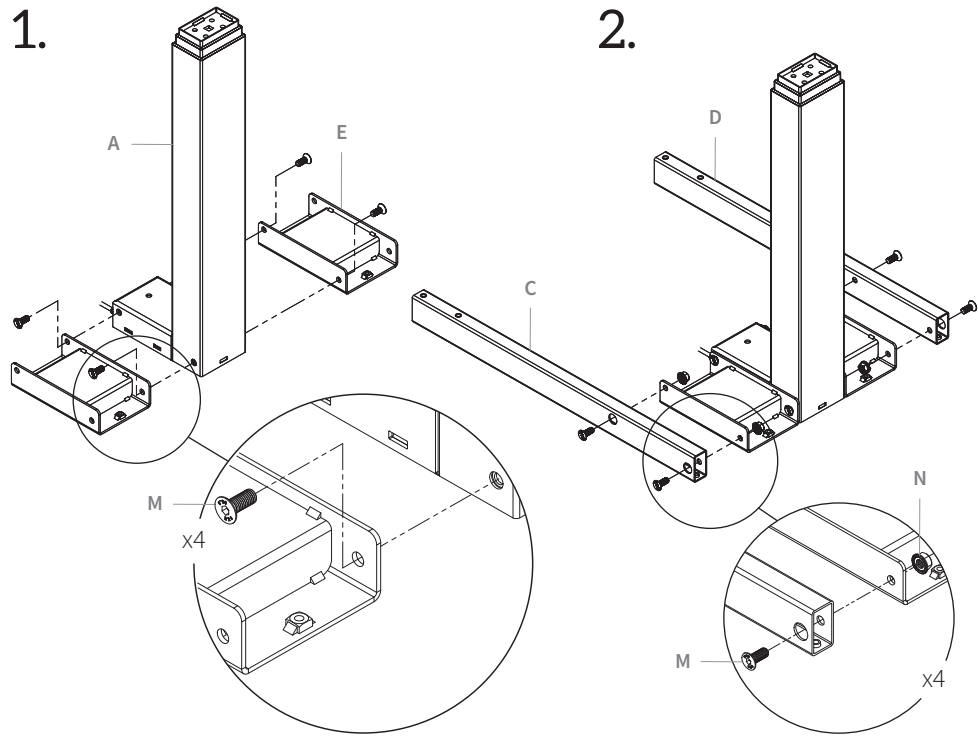

7.

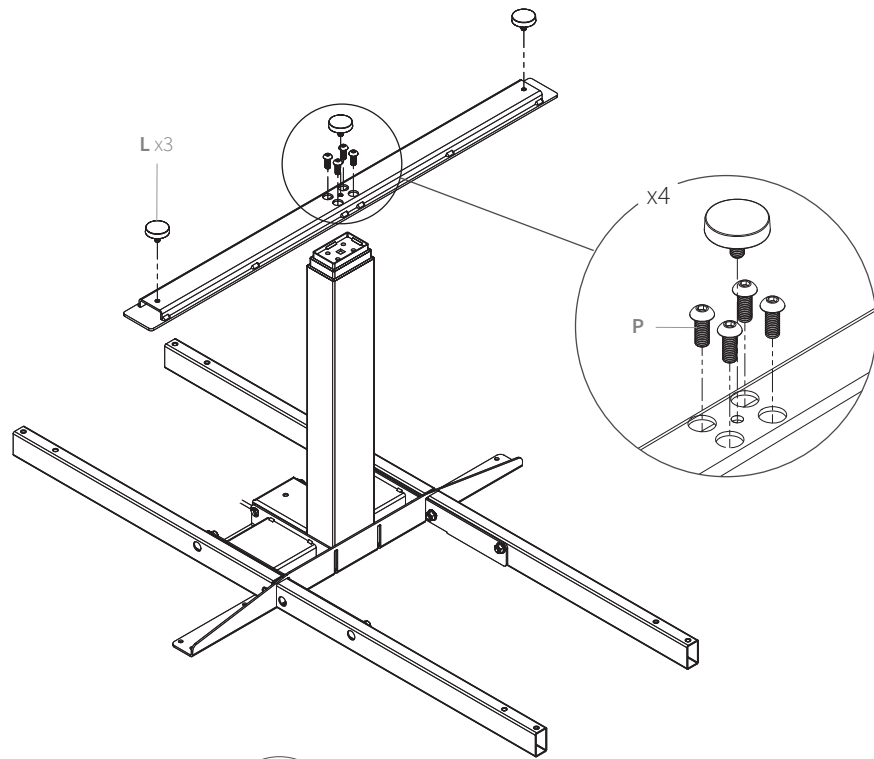

8.

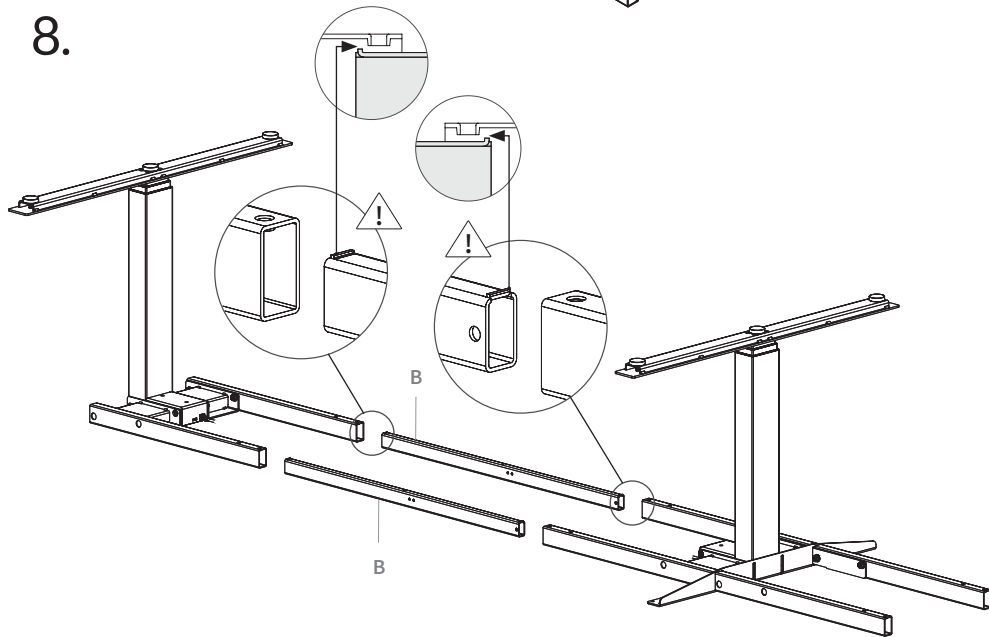

9.

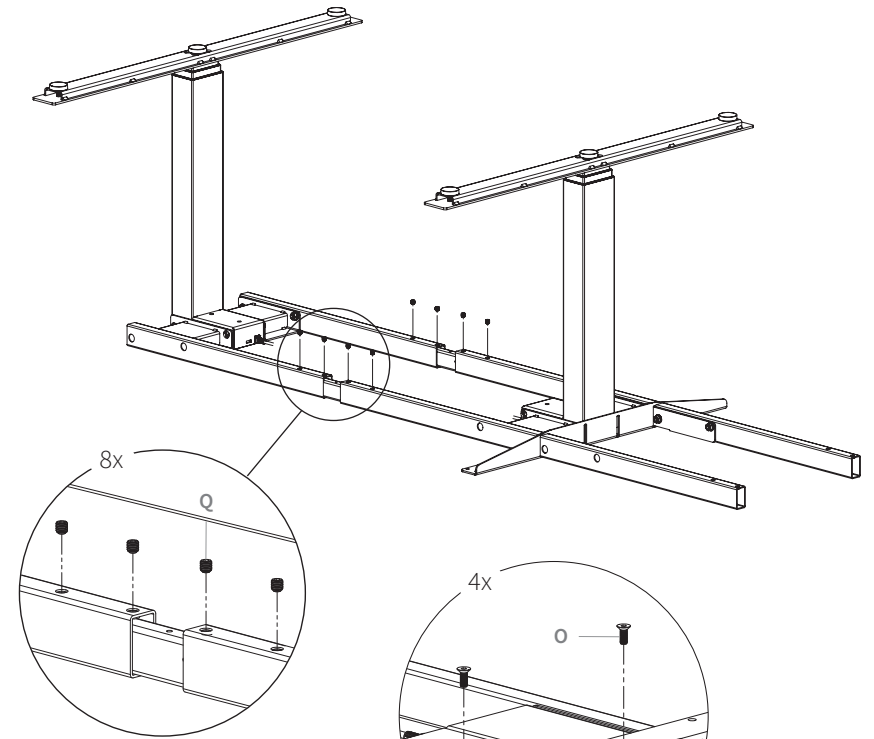

10.

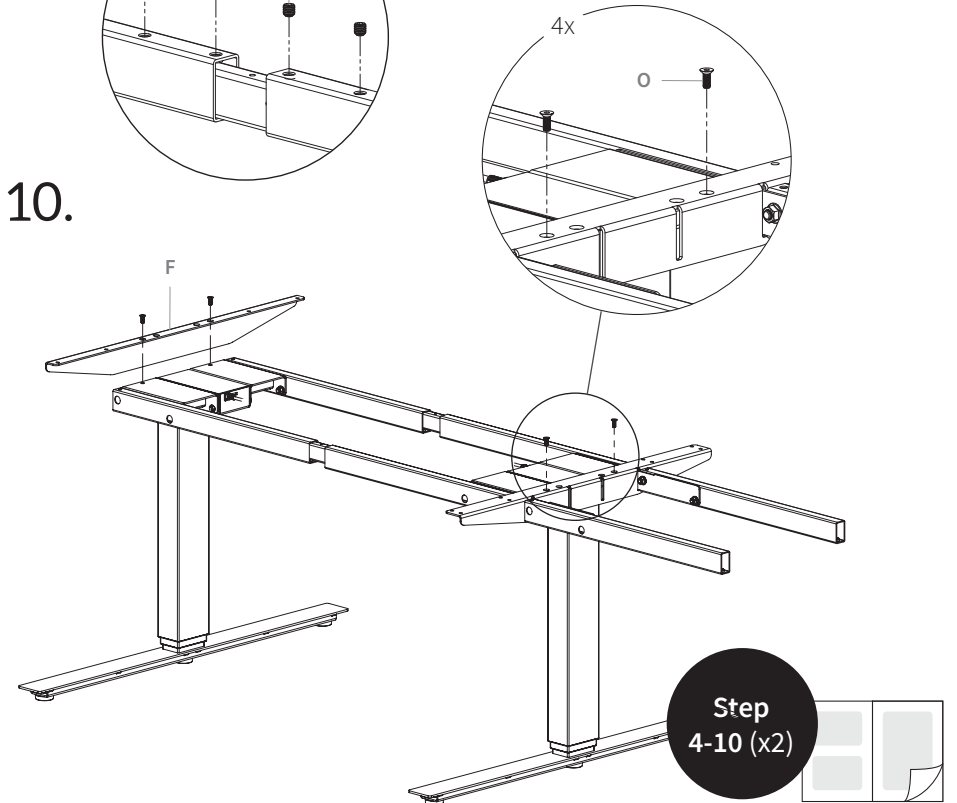

Step
4-10 (x2)

11.

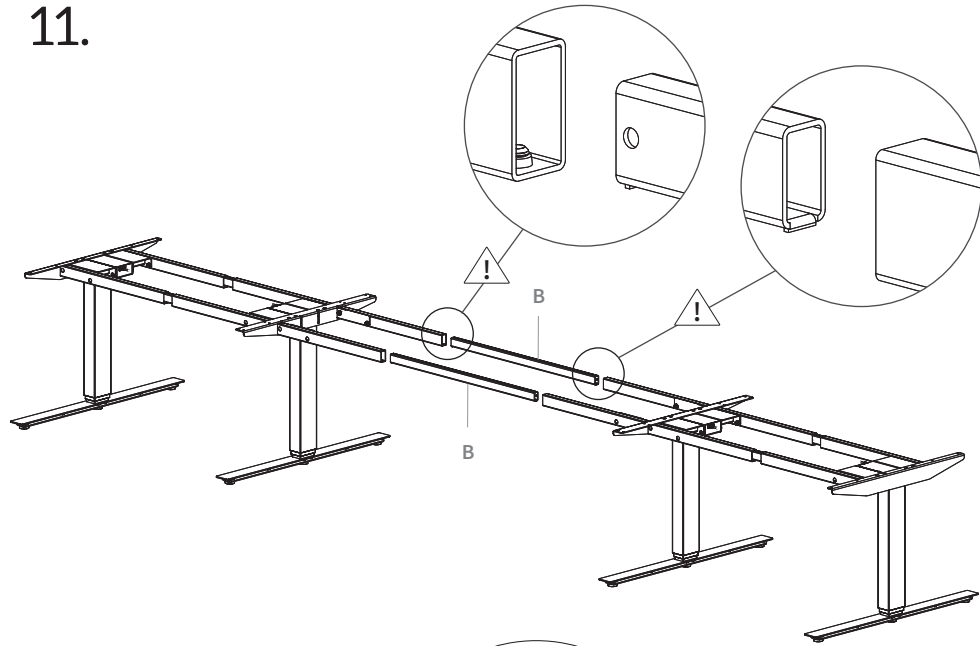

12.

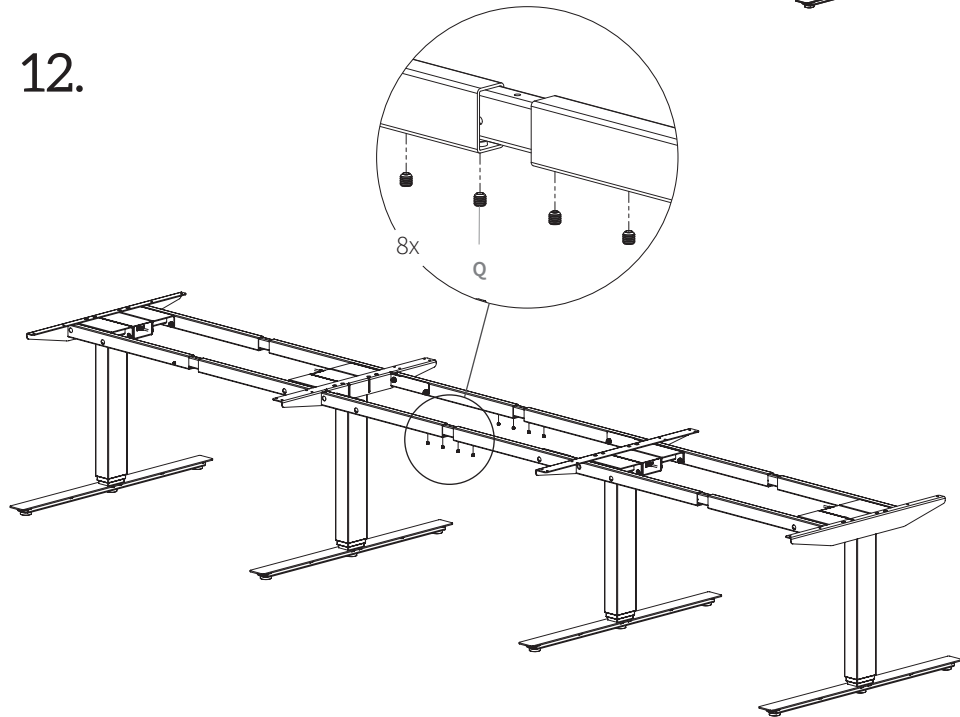

13.

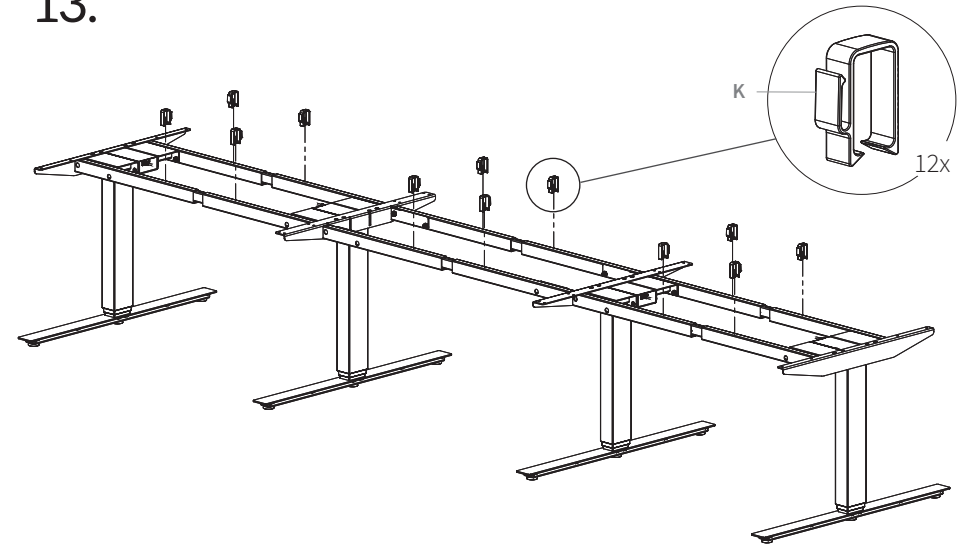

14.

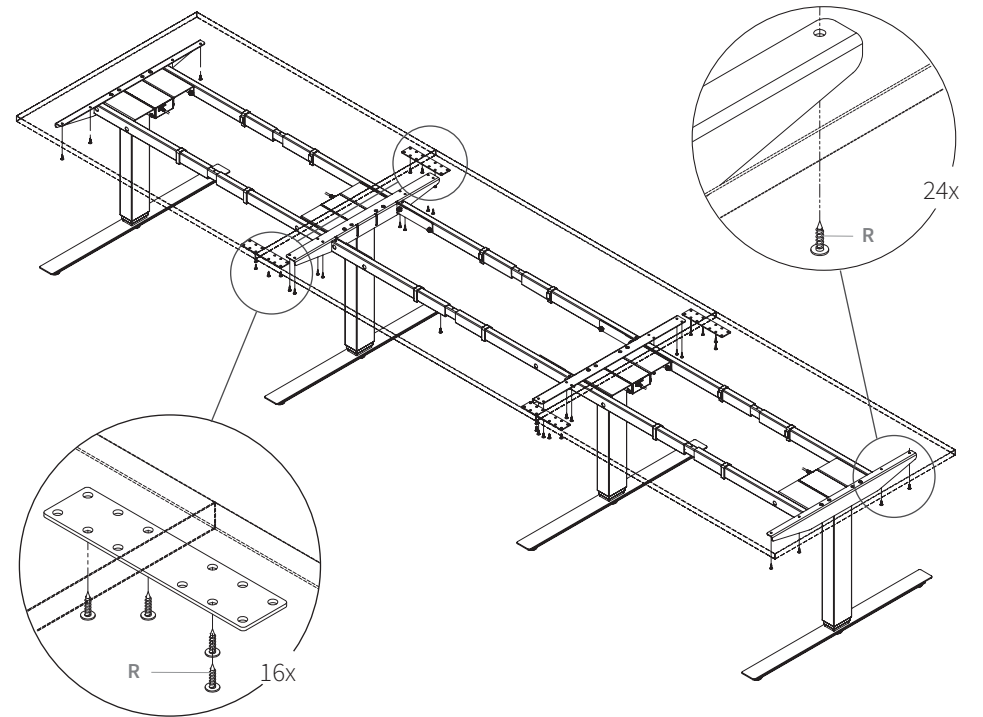

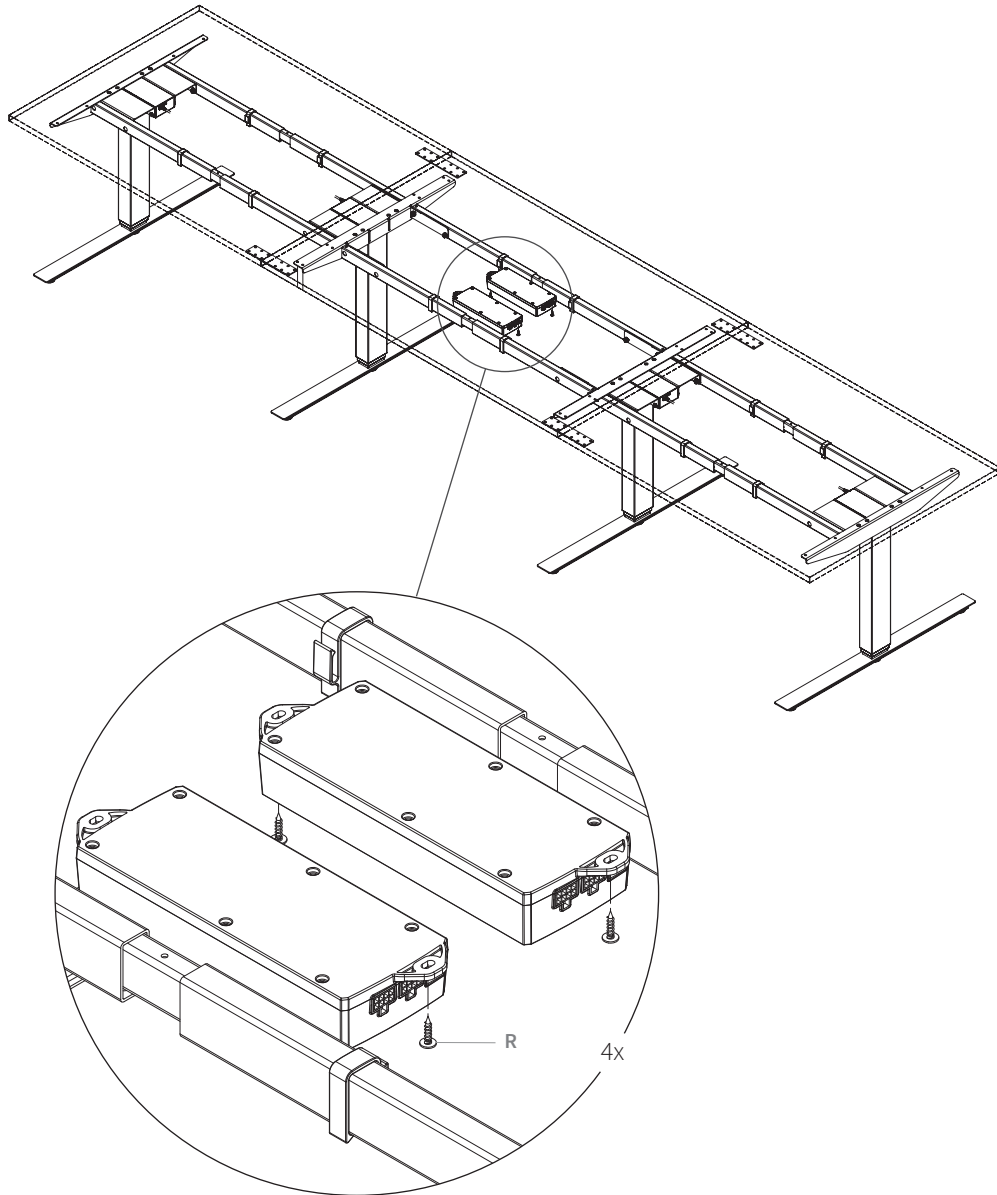

Electric height adjustable A-4 AERO Conference
Elektriskt justerbart höj-sänkbart A-4 AERO Konferens
Elektrisch höhenverstellbarer A-4 AERO Konferenz

Make sure the control boxes are not powered. Connect the motor cables and extension cables to the control boxes.

Försäkra dig om att styrenheterna inte är strömsatta. Anslut sedan motorkablarna och förlängningskablarna till styrenheterna.

Stellen Sie sicher, dass die Steuerboxen nicht mit Strom versorgt werden. Schließen Sie die Motorkabel und Verlängerungskabel an die Steuerbox an.

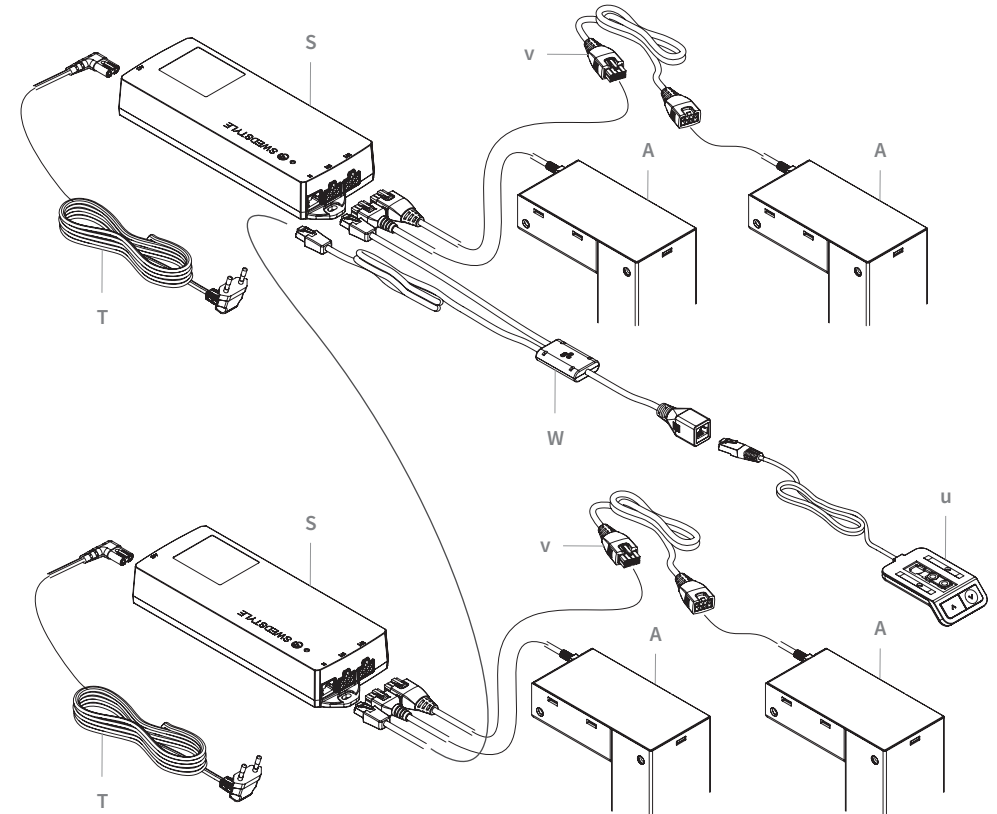

1. Connect the two control boxes using the cascade cable.
2. Connect the power supply to the using the power cord. WAIT 10 SECONDS. Short clicks will sound from each control box.
3. Before using the table, perform the reset procedure. See page 25.

1. Koppla samman de båda styrenheterna med kaskadkabeln.
2. Koppla in strömladdan till . VÄNTA 10 SEKUNDER. Korta klickande ljud kommer att ljuda från varje styrenhet.
3. Innan stativet används måste en nollställning utföras. Se sid 25.

1. Verbinden Sie die beiden Steuerkästen mit dem Kaskadenkabel
2. Verbinden Sie das Netzteil mit dem Netzkabel. Warten Sie 10 Sekunden. Kurze Klicks ertönen aus jedem Kontrollkästchen.
3. Vor der Verwendung des Gestell muss ein Reset durchgeführt werden. Siehe Seite 25.

EN

Lower the frame to its lowest position by pressing the down arrow on the hand control. Release the button. Press the button again and keep it pressed for 10 seconds, the reset is now carried out and the frame is ready to use.

SE

Kör bordet till stativets bottenläge genom att trycka på knappen "pil ned", när stativet nått lägsta läget så släpp knappen. Tryck sedan in den på nytt och håll inne ytterligare 10 sek. Stativet är nu nollställt och redo att användas.

DE

Fahren Sie die Tischplatte mit der Taste "Pfeil nach unten" zum tiefsten Punkt! Die Taste loslassen. Die Taste noch einmal herunterdrücken und sie ca. 10 Sekunden halten bis Sie eine kleine Bewegung der Tischplatte bemerken.

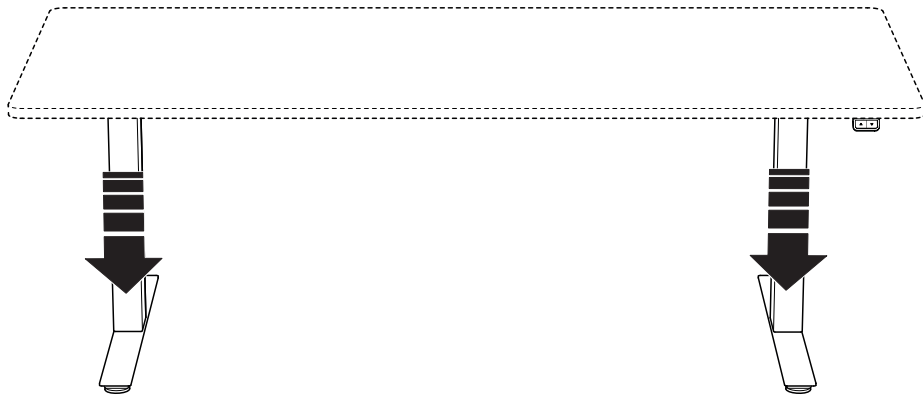
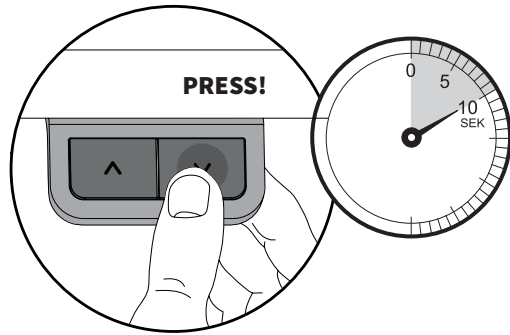

Smart office solutions